

Shielding Box Series MSB



MTS Shielding Box - Series MSB:

Application

For measurements and tests of electronic devices such as mobile phones, notebooks, evaluation boards etc. without electromagnetic disturbances from the environment.

Description

MTS Systemtechnik GmbH has developed a compact and movable EMC screened 'room', to fulfil multi-purpose requirements. The stable construction of the shielding box series MSB is predestined for high test appearance due to the easy, single-handed open-close function. The test devices can either be clamped into an universal mobile phone attachment or put simply into the shielding box. The operation of the test samples can be done directly through the built-in flexible wire mesh or by using the numerous included communication interfaces.



Mean Shielding 500 MHz - 6000 MHz (MSB-0200)

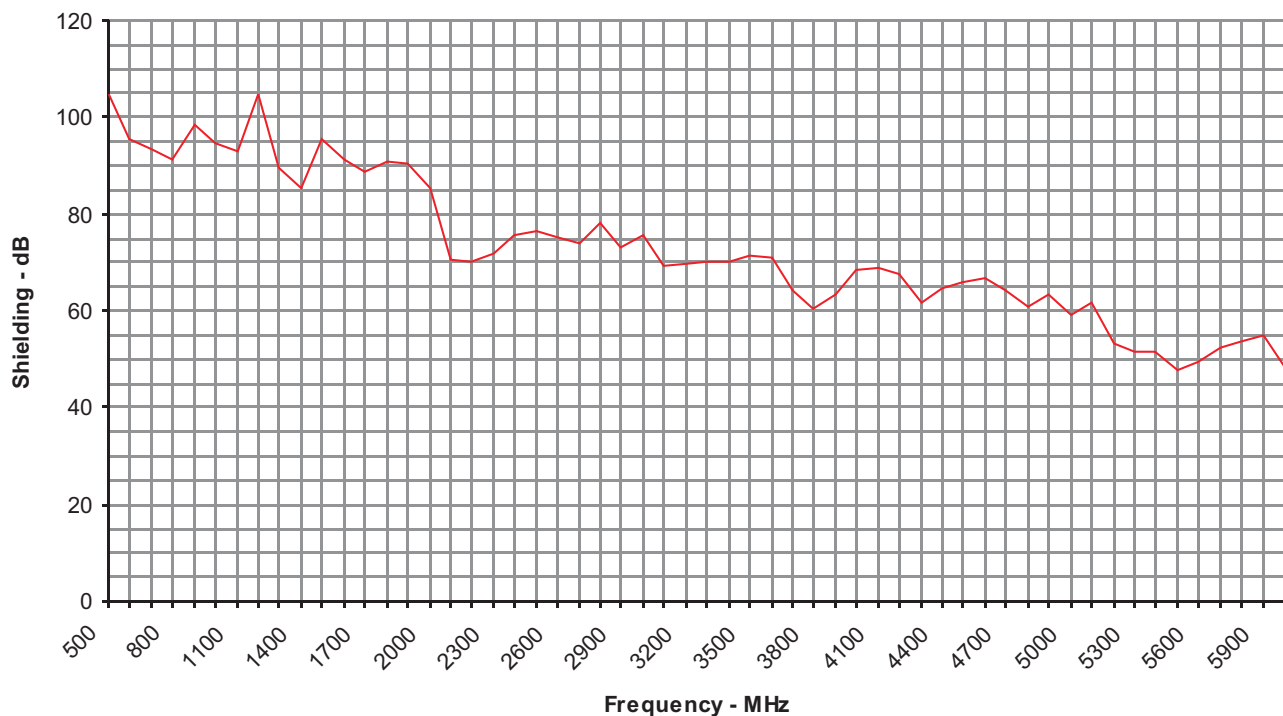

Characteristics:

- Highest quality materials for extended life-time and high test appearance.
- Economical solution for very high RF shielding levels and reproducible test scenarios to avoid time-consuming and expensive tests at EMC laboratories.
- Usable for frequencies between 500-6000 MHz, such as GSM/DCS/DECT/UMTS/RFID/ZigBee/Bluetooth/WLAN etc.
- Easy operation of the test samples directly through the built-in flexible wire mesh.
- Weight optimized structure improves the mobility.
- Highest safety standards through increased slip resistance and gas prop cover holder.
- Integrated universal attachment for most types of mobile phones.
- A wide range of supply and communication interfaces are included as standard.
- Optional: interfaces and connectors to customers specifications.
- Shielding boxes with other dimensions can be designed according to customers individual requirements.

Interfaces:

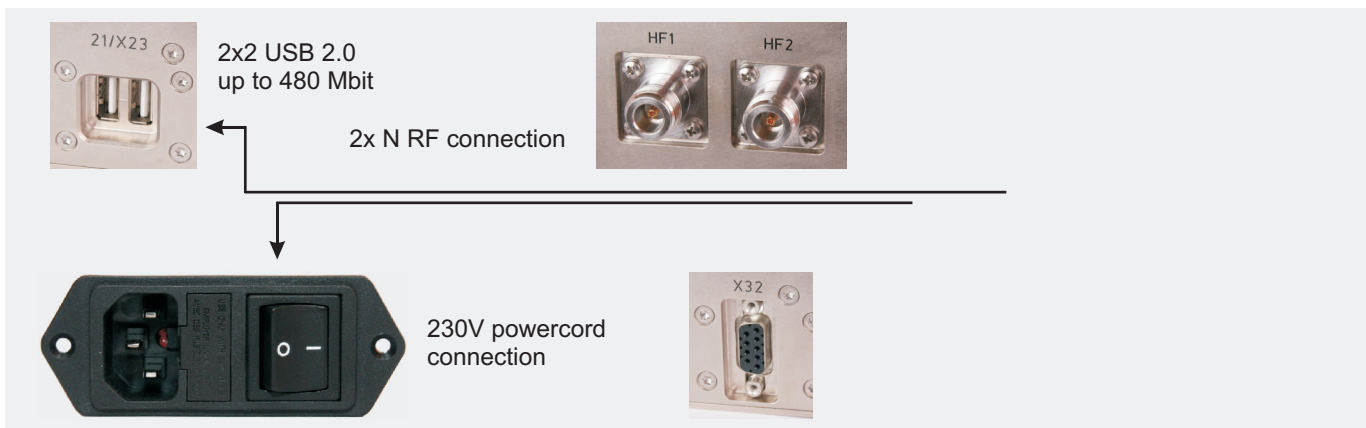

Dimensions:

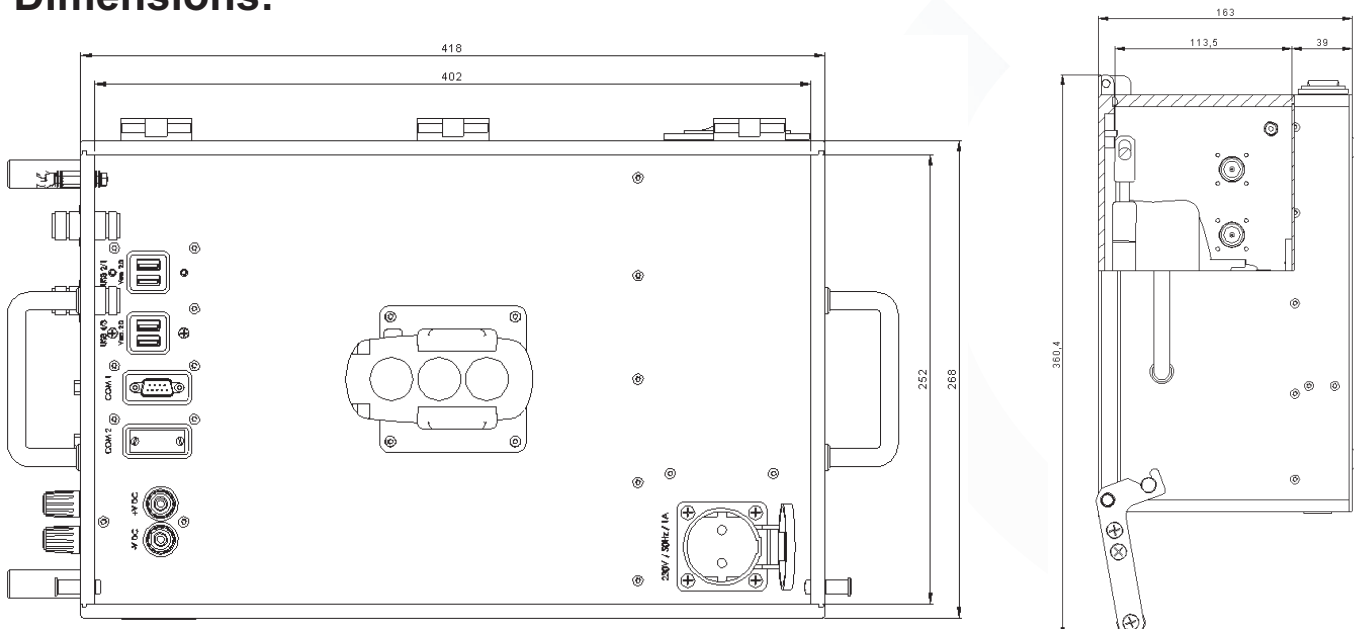

RF-systems and -units

EMC / Antenna Technology

Mechanical products

Certified with DIN ISO 9001:2000

Gewerbepark Ost 8
D-86690 Mertingen
Germany
Phone: +49 (0) 90 78 / 9 12 94-0
Fax: +49 (0) 90 78 / 9 12 94-70
info@mts-systemtechnik.de
www.mts-systemtechnik.de

Further information

Do not hesitate and order our free brochures and catalogues in German or English today. In our catalogue for mechanical parts you will find a large selection of standard enclosures mostly ex stock and deliverable at short notice. Please visit our website to get an overview about our product range.

Further
information



References

Today notable companies of the electronic industry all over Europe belong to our customers:

- Apple
- Alcatel
- Arpege Défence
- Audi
- Bosch Motorsport
- Bosch
- Cern
- Danet
- DB Telematik
- DESY
- Diehl Aerospace
- DLR
- EADS
- Ericsson
- ESA
- Eurocopter
- Huawei
- Infineon
- Jenaer Antriebstechnik
- Leica
- Lucent Technologie
- ND SatCom
- O₂
- Omicron
- PTB
- RIM
- Rohde & Schwarz
- SBS
- Serco
- Siemens
- Tesat
- Thomson
- T-Mobile
- Vodafone

References

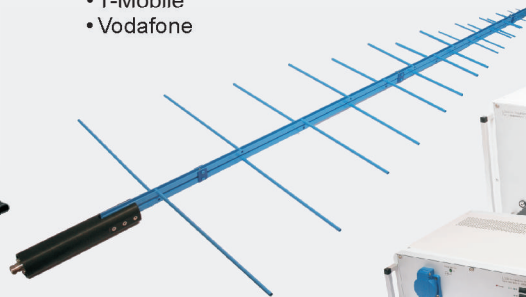

The company MTS would like to introduce itself:

The MTS Systemtechnik GmbH is a flexible and middle-sized company, which was founded in 1980 as a development and production company. Since then the MTS's special field is the distribution and modification of RF-signals. Nowadays we manufacture products and systems for the mobile radio, laboratory, satellite communication and video respectively audio field.

Following you can find our product range in extracts:

Systems and Units

- Antenna- / Signal distribution units
- Remote controlled switching units
- Filter units
- Ventilation units
- Matrices
- Coupling units
- Air field emulations serie AIAD
- Shielding boxes serie MSB

Components

- Coaxial relays
- Multi channel switches
- Videorelays
- Feedthrough terminations
- DC-blocks
- Fixed attenuators
- Terminations
- Semiconductor -switches & - attenuators
- Coaxial short circuits, bias tees
- Power attenuators and power terminations

- Signal dividers, power splitters, combiners and directional couplers
- Programmable step attenuators
- Coaxial cable assemblies
- Impedance matching modules
- PC controlled components
- Amplifiers

Mechanical Modules

- RF shielded enclosures
- Structural enclosures
- Customer specified enclosures
- Milled components
- Milled cassettes
- Cassette enclosures
- 19"-racks

Data Technology

- Controller cards and accessories for operators in electronic
- Development of firm- and software according to customer's wishes

EMC / Antenna Technology

- LISN - Line Impedance Stabilisation Network
- EMC Components
- Antennas and accessories
- Wireless LAN Sets

Services

- CAD development and customer specified CNC milled modules
- Mounting of components to and testing of RF printed circuit boards
- Engineering service
- Programming service

Distribution for IMS Connector Systems GmbH

- Coaxial connectors
- Terminations
- Coaxial adapters
- Coaxial cable assemblies

Product
overview