

## EGD series

Beside plug-in modules of the EG series, we produce 19" plug-in modules with RF shield (EGD series) also. In spite of the proved slot and spring principle, it is only possible to remove the cover and the bottom from the front and rear panel without dismantling, if the parts get over-worked. Special drillings and millings on request. Other dimensions on request.

### Surface

Standard: Aluminum vibratory finishing. Following surfaces are optionally available: Alodyned (low priced surface protection), chemical nickel-plated (corrosion resisting), optimal shield of magnetic source of interference (see technical information).

### Content of delivery

Each 19" plug-in module is packed and delivered as a complete set including all necessary mounting screws. Front panels won't have drill holes, if ordered without handles.

### Special versions

We also deliver 19" plug-in module on request.

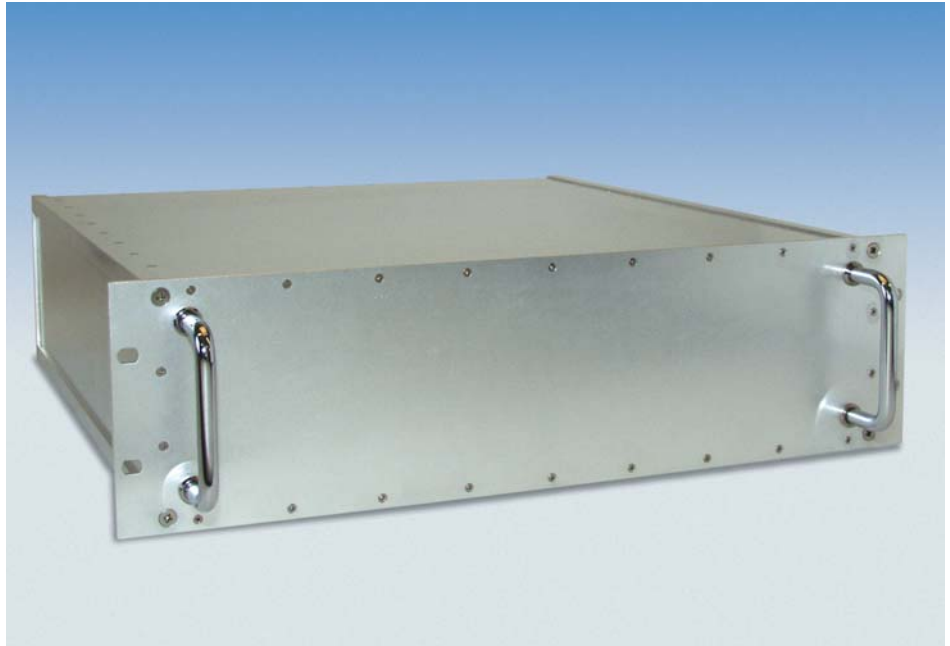

## Technical information, EGD series

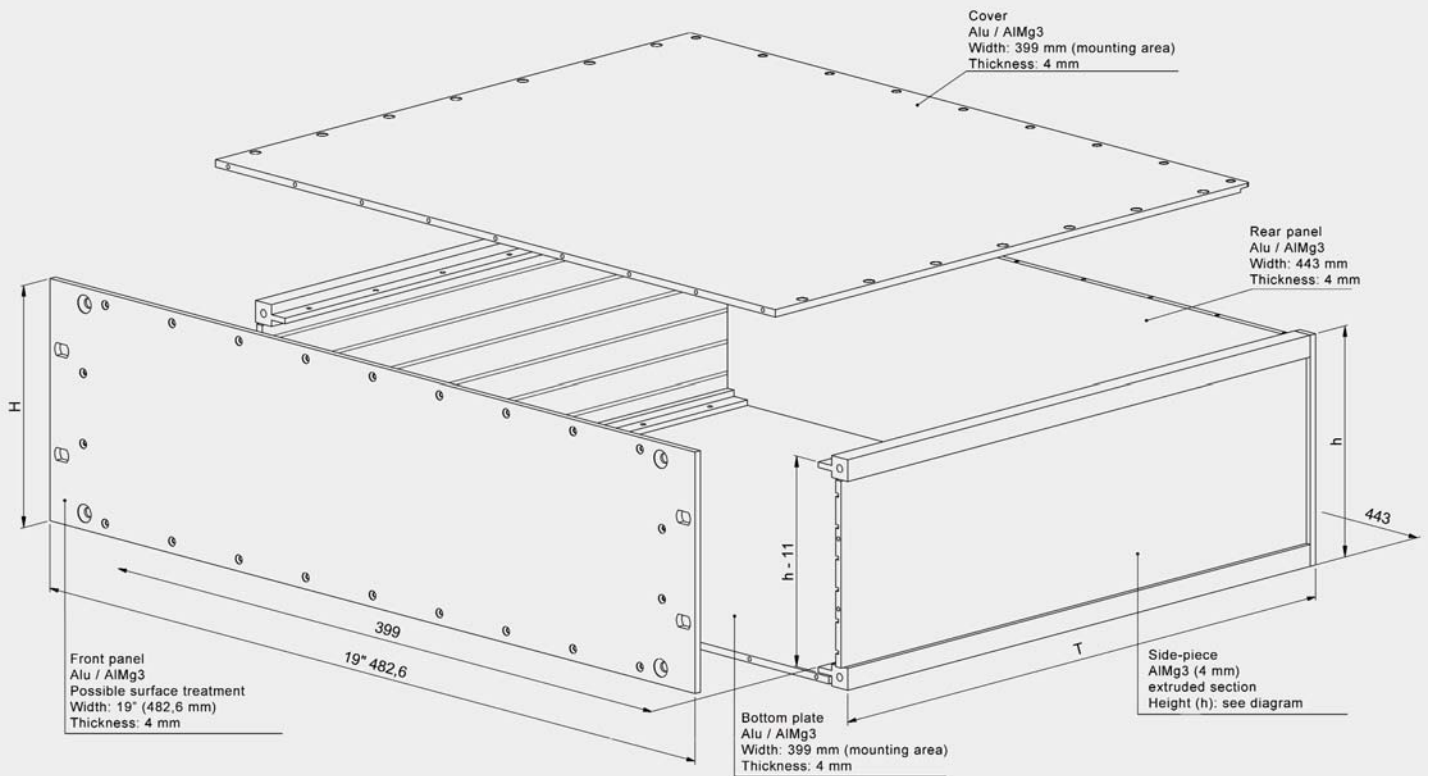

### Dimensions of enclosures, EGD series

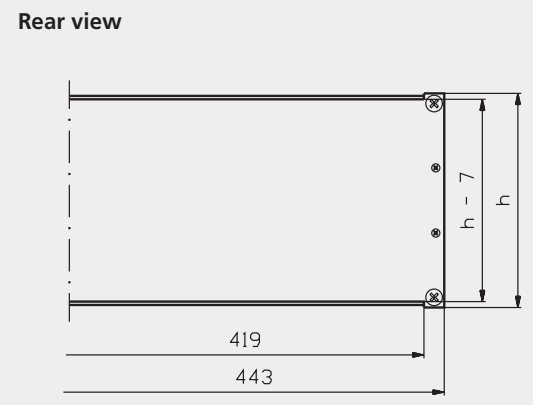
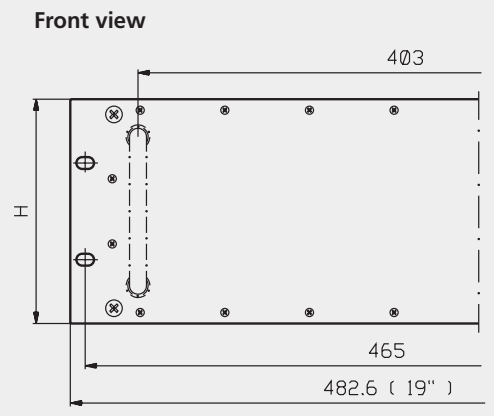
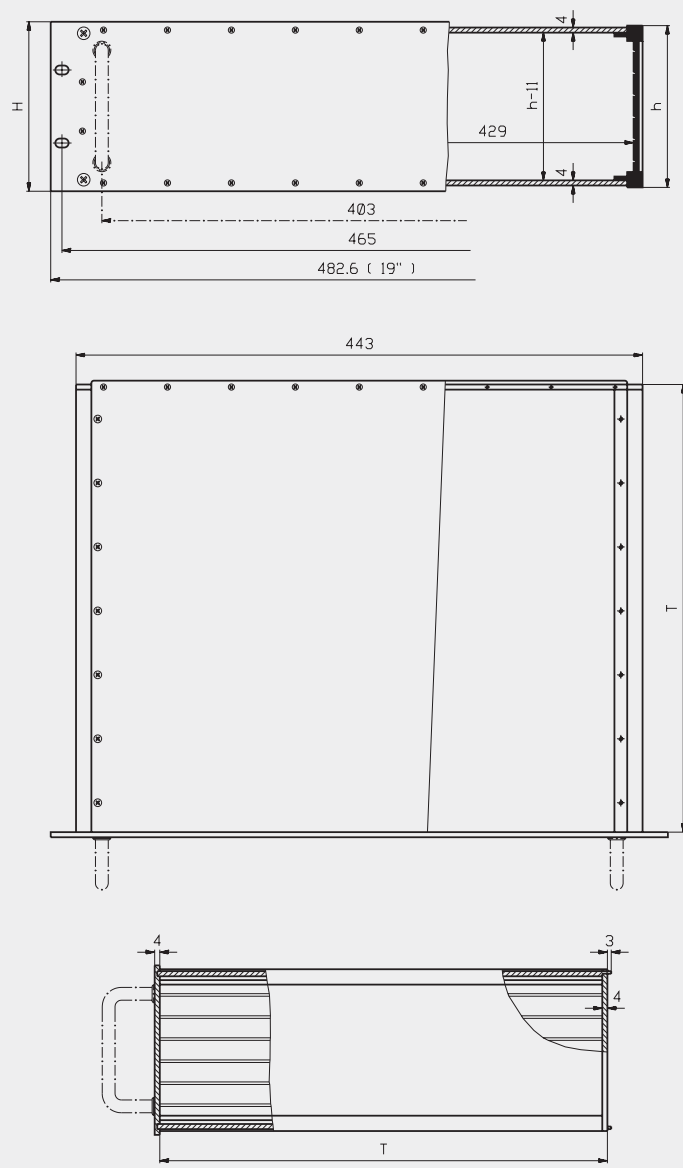

Drill holes for handles, only if ordered.

Dimensions in mm

### Configuration of model designation

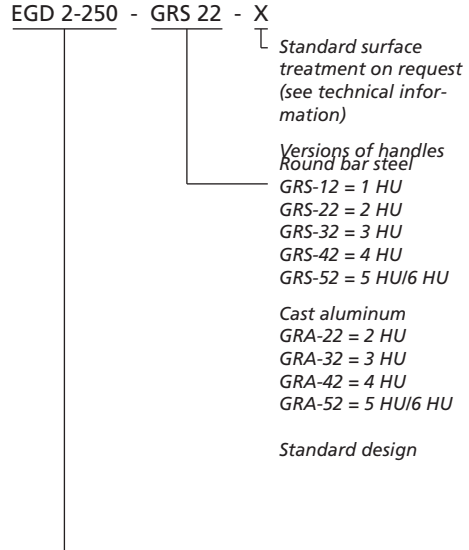

### Dimensions of 19"-front and rear panels

Design	Height of units	front panel in mm	rear panel in mm
EGD2	2 HE	482,6 x 88,1 x 4	443 x 82,0 x 4
EGD3	3 HE	482,6 x 132,5 x 4	443 x 126,0 x 4
EGD4	4 HE	482,6 x 177,0 x 4	443 x 171,0 x 4
EGD5	5 HE	482,6 x 221,4 x 4	443 x 208,5 x 4
EGD6	6 HE	482,6 x 265,9 x 4	443 x 253,0 x 4

Further information see chapter "accessories", FP series.

### Standard designs

Depth T (mm)	2 HE h = 82 mm	3 HE h = 126,5 mm	4 HE h = 171 mm	5HE h = 208,5 mm	6 HE h = 253 mm
250	EGD2-250	EGD3-250	EGD4-250	EGD5-250	EGD6-250
350	EGD2-350	EGD3-350	EGD4-350	EGD5-350	EGD6-350
450	EGD2-450	EGD3-450	EGD4-450	EGD5-450	EGD6-450